

# Owner's Manual And Assembly Instructions



## The Ventura

Model 1-AP008



# Adventure Playsets

Amarillo Texas 79119

Thank you for purchasing an Adventure Playsets Playcenter. We hope it will bring you and your children many years of safe and enjoyable backyard fun.

## Table of Contents

Letter to Customer .....	1
Positioning Your Playcenter .....	2
Tools Required for Assembly .....	2
Helpful Installation Hints .....	2
Suggested Playground Surfacing .....	3
Operating Instructions .....	4
Maintenance Instructions .....	5
Disposal Instructions .....	6
CPSC Information Sheet .....	7
Assembly Instructions .....	8
Customer Notes .....	30
Limited Warranty .....	31
Warranty Claim Procedure .....	32
Customer Registration Card .....	33

Your owner's manual should be read carefully before starting assembly.

Dear Customer:

Thank you for purchasing an Adventure Playsets Playcenter. We hope it will bring you and your children many years of safe and enjoyable backyard fun. Adventure Playsets equipment is recommended for use by **children 3 to 10 years of age**. Adventure Playsets structures are **not intended for public use**. **Adventure Playsets does not warranty any of its residential structures subjected to commercial use.**

Please follow all recommendations below. **Failure to do so may result in the warranty being void and/or safety violations that could result in serious injury.** The following information has been provided to help you in your installation, continued satisfaction, and safe operation of your Adventure Playsets purchase.

Always keep the safety of your children in mind as your play structure is being built and as your children play on the set. **Children must not use the Playcenter until completely assembled and properly installed and anchored to prevent serious injury.** Before your children play on the set please review the Operation Instructions with them to help ensure their safety.

**PLEASE RETAIN THESE INSTRUCTIONS FOR FUTURE REFERENCE.**  
**KEEP THEM IN A SAFE PLACE WHERE YOU CAN REFER TO THEM AS NEEDED.**

***General Information:***

<b><u>Manufacturer</u></b>	Adventure Playsets 14201 Interstate 27 Amarillo, TX 79119 Ph. #: 1-800-856-4445 Fax: 806-622-1515 E-mail – <a href="mailto:custservice@adventureplaysets.com">custservice@adventureplaysets.com</a>	<b><u>Dealer:</u></b> _____ _____ _____ _____
----------------------------	--	--

**Unit Type:**

Unit Name: The Ventura                      Revision Date: 01/07/04  
Unit Model Number:                      ÿ Model: 1-AP008  
Instruction Manual Information

Maximum Fall Height:                      7'-6"

The instructions and owner's manual for your new Playcenter should be read in its entirety before assembly, to minimize problems and safety issues. We recommend reading the owner's manual thoroughly after you have identified all of the parts for your Playcenter as discussed in the Helpful Installations Hints section below.

## ***Positioning Your Play center***

1. The Playcenter is designed to be installed on a level surface. Try to place in a flat area of your yard to minimize ground preparation.
2. Place the equipment not less than 6 ft from any structure or obstruction such as a fence, garage, house, overhanging branches, laundry lines, or electrical wires.
3. It is a good idea to place your Playcenter in an area that is convenient for adults to watch children at play.
4. The area that you choose should be policed for glass, rocks or anything jagged or sharp that could endanger your children's safety. The surface underneath your play system can cause or prevent injuries. We have additional suggestions in the Suggested Playground Surfacing Section.
5. Do not build your playset on top of surfacing material.

## ***Anchoring Instructions***

Anchoring instructions are included in the installation instructions along with 6 wooden anchoring stakes for normal installations. Adventure Playsets has for sale an optional accessory, Anchor It kit, which should be used if the Playcenter is to be used in sandy soil. The kit includes 4 powder coated anchors, fully illustrated plans, and all the hardware required for installation. For information on how to purchase this kit call 1-800-856-4445.

## ***Tools Required for Installation:***

1. 3/8" Drill
2. 5/16" and 3/8" Drill bits
3. 7/16" Box Wrench or 3/8"-drive socket
4. Two 1/2" Box Wrenches or 3/8"-drive sockets
5. 3/8"-drive ratchet or 3/8"-drive socket adapter for drill if sockets are used
6. #2 and #3 Phillips bit for drill (preferred) or #2 and #3 Phillips screwdriver
7. Flat screwdriver
8. Tape measure
9. Level
10. Hammer
11. Allen Wrench (included with hardware)
12. An Adult with an Adult Helper

## ***Helpful Installation Hints***

1. Depending on your experience, assembly of this Playset should take approximately 6 to 12 hours after inventory of parts. Therefore, we recommend you set aside a full day for assembly.
2. Identify all of the parts for your Playcenter. Empty each box and lay out boards so you can see each part. Your instruction book will have detailed drawings that

- will make it easy for you to recognize individual parts. Keep all hardware and metal parts separate from wooden pieces.
3. After everything is laid out, check carefully to ensure all parts are present. Make sure there are no broken boards.
  4. Find an area to sort your hardware. It is best to open the hardware on a solid surface so that you do not lose any pieces in the grass. This will save time and familiarize you with all the different pieces in the hardware bag.
  5. Important note: Wood has some natural defects such as knots, surface cracks, etc... We reject parts that are structurally defective. We use a high quality lumber in our structures; however, you should inspect each part for splinters or rough spots and sand them smooth to prevent injury.
  6. After steps 1 thru 4 have been completed, read all the way through the instructions completely. Reading instructions after you have studied the parts will help you understand more clearly the installation process, and help to eliminate unnecessary mistakes.
  7. Pay close attention to the diameter and length of each bolt and screw. There will be different sizes in the same bag, so they must be sorted correctly.
  8. Swing hangers should be buried past the threads, so that the loop is against the swing beam. Adventure Playsets is not responsible for incorrect installations of swing hangers. Failure to properly install swing hangers may cause severe injury.
  9. Never tighten hardware completely at first. It helps to have some adjustment for bolt alignment while you are attaching parts together. After everything is square, tighten each joint.
  10. After the main unit is assembled it is critical that the floor is level and square. If the main frame is not level, the walls and floor will be out of square.
  11. After you complete installation, make sure every bolt, screw, and nut is tight, and every board is secure. Wood will expand and contract with the seasons. Check all bolt connections and swing hangers every two weeks.

### **READ! VERY IMPORTANT!**

If you are missing parts or have questions regarding the installation of our quality product PLEASE call us directly at the factory (1-800-856-4445). Our trained staff will be happy to assist you.

**Customer service hours:**  
**Monday thru Friday 9am to 5pm**  
**Saturday 9am to 2pm**  
**Central Standard Time.**

E-mail: [custservice@adventureplaysets.com](mailto:custservice@adventureplaysets.com)

### ***Suggested Playground Surfacing***

- Playground equipment should never be placed on hard surfaces such as concrete or asphalt.

- ❑ Shredded bark mulch, wood chips, fine sand and fine gravel, are added as shock absorbing materials after assembly. If used properly these materials can absorb some of the impact of a child’s fall.
- ❑ All surface material should extend a minimum of 6 feet in all directions around the play area.

**The following chart explains the fall height in feet from which a life threatening head injury would not be expected**

### Critical Heights (in feet) of Tested Materials

<u>Material</u>	<u>Uncompressed depth</u>			<u>Compressed depth</u>
	<u>6 in.</u>	<u>9 in.</u>	<u>12 in.</u>	<u>to 9 in.</u>
Wood Chips	7	10	11	10
Double-shredded bark mulch	6	10	11	7
Engineered Wood Fibers	6	7	>12	6
Fine Sand	5	5	9	5
Coarse Sand	5	5	6	4
Fine Gravel	6	7	10	6
Medium Gravel	5	5	6	5
Shredded Tires*	10-12	N/A	N/A	N/A

\*This data is from tests conducted by independent testing laboratories on a 6-inch depth of uncompressed shredded tire samples produced by four manufacturers. The tests reported critical heights, which varied from 10 feet to greater than 12 feet. It is recommended that persons seeking to install shredded tires as a protective surface request test data from the supplier showing the critical height of the material when it was tested in accordance with ASTM F1292.

This information is intended to assist you in comparing the relative shock absorbing properties of various materials. Each material is only effective when it is properly maintained at the proper depths determined necessary for your equipment.

### ***Operating Instructions:***

NOTE: Your children’s safety is our #1 concern. Observing the following statements and warnings reduces the likelihood of serious or fatal injury. Please review these safety rules regularly with your children.

1. This Playcenter is designed for the use of 3 occupants who have a combined weight not exceeding 280 pounds.
2. On-site adult supervision is **required**.
3. Instruct children **not** to walk close to, in front of, behind, or between moving swings or other moving playground equipment.
4. Instruct children to sit in and **never** stand on swings
5. Instruct children **not** to twist the chains and ropes and not to loop them over the top support bar, since this may reduce the strength of the chain or rope.

6. Instruct children **not** to jump from swings or other playground equipment in motion.
7. Instruct children to **not push** empty seats. The seat may hit them and cause serious injury.
8. Instruct and teach children to sit in the center of the swings with their full weight on the seats.
9. Instruct children **not** to use the equipment in a manner other than intended.
10. Instruct children to **always** go down slides feet first. Never slide headfirst.
11. Instruct children to **look** before they slide to make sure no one is at the bottom.
12. Instruct children to **never** run up a slide, as this increases their chances of falling.
13. The parents should have the children **dress appropriately** with well-fitting shoes. Loose clothing such as scarves and ponchos should not be worn. Always take off, tie up or tuck in cords and drawstrings on children's clothing. These things can get caught on playground equipment and strangle a child.
14. Instruct children **not** to climb when the equipment is wet.
15. Instruct children to **never** jump from a fort deck. They should always use the ladder, ramp or slide.
16. Instruct children to **never** crawl or walk across the top of monkey bars.
17. Instruct children to **never** crawl on top of a fort roof.
18. Verify that any suspended climbing ropes, chain, or cable are secured at both ends and that they cannot be looped back on it.
19. Instruct children **not** to attach items to the playground equipment that are not specifically designed for use with the equipment, such as, but not limited to, jump ropes, clothesline, pet leashes, cables and chain as they may cause a strangulation hazard.

### ***Maintenance Instructions:***

1. Check all nuts and bolts twice monthly during the usage season and tighten as required. (But not so tight that you crack the wood) We recommend you check the swing beam and hardware every two weeks due to wood expansion and contraction. It is particularly important that this procedure be followed at the beginning of each season.
2. Remove plastic swing seats and take indoors or do not use when the temperature drops below 32 °F.
3. Oil all metallic moving parts monthly during the usage period.
4. Check all coverings for bolts and sharp edges twice monthly during usage season to be certain they are in place. Replace when necessary. It is especially important to do this at the beginning of each new season.
5. Check swing seats, ropes, cables and chains monthly during usage season for evidence of deterioration. Replacement should be made of any swing seat that has developed cracks in the plastic seats or has exposed metal in the edges of the swing seat. If there are already exposed metal inserts on the edge of the seat, immediately remove the seats and chains to prevent serious injury. Ropes, cables

- and chains should be removed and replaced if excessive wear is found. Contact Adventure Playsets for replacement parts.
6. For rusted areas on metallic members such as monkey bars, hand supports, brackets, etc., sand and repaint, using a non lead-based paint meeting the requirements of Title 16 CRF Part 1303.
  7. Inspect wood parts monthly. The grain of the wood sometimes will lift in the dry season causing splinters to appear. Light sanding may be necessary to maintain a safe playing environment. If you are treating your Playcenter with stain regularly, it will help prevent severe checking/splitting and other weather damage.
  8. We recommend treating the wood components once or twice a year depending on the type of weather you have and when sanding has been required to maintain a good surface. We treat our wood with a waterborne transparent stain.
  9. Creating and maintaining the Playcenter on a level location is very important. As your children play, your Playcenter will slowly dig its way into the soil, and it is very important that it settles evenly. Make sure the play set is level and true once each year or at the beginning of each play season.

***Disposal Instructions:***

When the Playcenter use is no longer desired, it should be disassembled and disposed of in such a way that no unreasonable hazards will exist at the time the unit is discarded.



## APPENDIX A

### *Information on Playground Surfacing Materials:*

The following information is from the *United States Consumer Product Safety Commission's Information Sheet for playground surfacing material*. Also see the following website for additional information: [www.cpsc.gov/cpscpub/pubs/323.html](http://www.cpsc.gov/cpscpub/pubs/323.html).

#### X3. CONSUMER INFORMATION SHEET FOR PLAYGROUND SURFACING MATERIALS<sup>11</sup>

X3.1 The U.S. Consumer Product Safety Commission (CPSC) estimates that about 100,000 playground equipment-related injuries resulting from falls to the ground surface are treated annually in U.S. hospital emergency rooms. Injuries involving this hazard pattern tend to be among the most serious of all playground injuries, and have the potential to be fatal, particularly when the injury is to the head. The surface under and around playground equipment can be a major factor in determining the injury-causing potential of a fall. It is self evident that a fall onto a shock-absorbing surface is less likely to cause a serious injury than a fall onto a hard surface. Playground equipment should never be placed on hard surfaces such as concrete or asphalt and while grass may appear to be acceptable it may quickly turn to hard packed earth in areas of high traffic. Shredded bark mulch, wood chips, fine sand or fine gravel are considered to be acceptable shock absorbing surfaces when installed and maintained at a sufficient depth under and around playground equipment.

X3.2 Table X3.1 lists the maximum height from which a child would not be expected to sustain a life-threatening head injury in a fall onto four different loose-fill surfacing materials if they are installed and maintained at depths of 6, 9, and 12 in. However, it should be recognized that all injuries due to falls cannot be prevented no matter what surfacing material is used.

X3.3 It is recommended that a shock absorbing material should extend a minimum of 6 ft in all directions from the perimeter of stationary equipment such as climbers and slides. However, because children may deliberately jump from a moving swing, the shock absorbing material should extend in the front and rear of a swing a minimum distance of 2 times the height of the pivot point measured from a point directly beneath the pivot on the supporting structure.

X3.4 This information is intended to assist in comparing the relative shock-absorbing properties of various materials. No particular material is recommended over another. However, each material is only effective when properly maintained. Materials should be checked periodically and replenished to maintain correct depth as determined necessary for your equipment. The choice of a material depends on the type and height of the playground equipment, the availability of the material in your area, and its cost.

<sup>11</sup>This information has been extracted from the CPSC publications "Playground Surfacing — Technical Information Guide" and "Handbook for Public Playground Safety." Copies of these reports can be obtained by sending a postcard to: Office of Public Affairs, U.S. Consumer Product Safety Commission, Washington, D.C., 20207 or call the toll-free hotline: 1-800-638-2772.

The American Society for Testing and Materials takes no position respecting the validity of any parent right asserted in connection with any item mentioned in this standard. Users of this standard are expressly advised that determination of the validity of any such parent rights, and the risk of infringement of such rights, are entirely their own responsibility.

The standard is subject to revision at any time by the responsible technical committee and must be reviewed every five years and if not revised, either approved or withdrawn. Your comments are invited either for revision of this standard or for additional standards and should be addressed to ASTM Headquarters. Your comments will receive careful consideration at a meeting of the responsible technical committee, which you may attend. If you feel that your comments have not received a fair hearing you should make your views known to the ASTM Committee on Standards, 100 Barr Harbor Drive, West Conshohocken, PA 19428.

# The Ventura Assembly Instructions



BASIC SETUP DIMENSIONS:

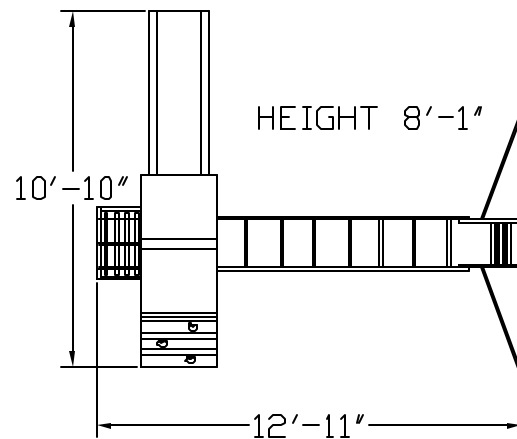

# SPLIT WASHER INSTRUCTIONS

THROUGHOUT THESE INSTRUCTIONS, WHEN USING A T-NUT, A SPLIT WASHER MUST BE USED BETWEEN THE HEAD OF THE HEX BOLT & THE FLAT WASHER. USING THESE WASHERS WILL KEEP HEX BOLTS FROM LOOSENING FROM THE T-NUT.

IF USING A 1/4" HEX BOLT, A 1/4" WASHER MUST BE USED AND IF USING A 5/16" HEX BOLT, A 5/16" WASHER MUST BE USED.

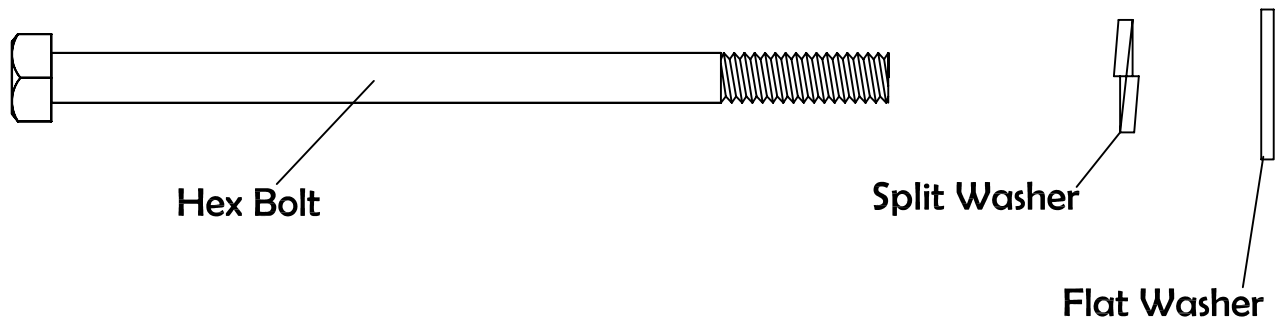

## HOW TO MEASURE A BOLT

NOTE: DO NOT INCLUDE BOLT HEAD WHEN MEASURING LENGTH OF BOLT.

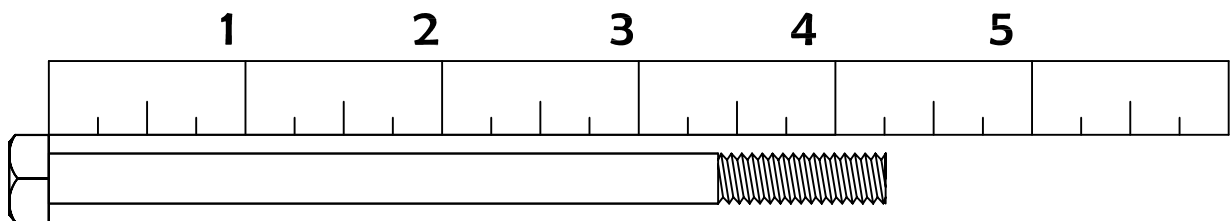

# HARDWARE IDENTIFICATION

## FORT HARDWARE BAG

(Hardware is to scale)

## 5/16" FLAT WASHERS

16

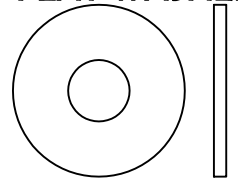

## 5/16" x 4 1/4" HEX BOLTS

4

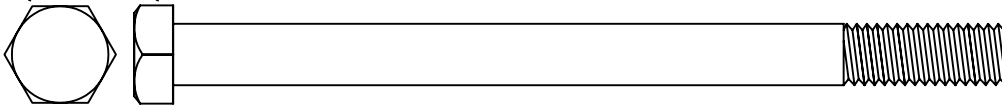

## 1/4 x 4 1/4" HEX BOLTS

4

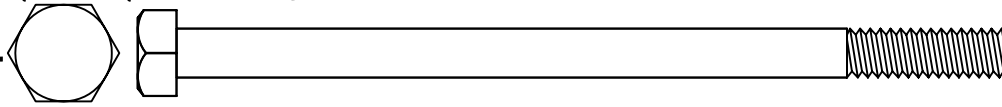

## 1/4 x 4" HEX BOLTS

3

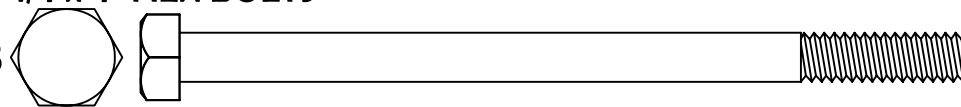

## 5/16" x 2 3/4" HEX BOLTS

2

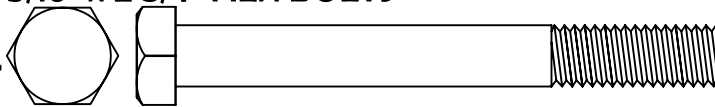

## 1/4 x 2 3/4" HEX BOLTS

2

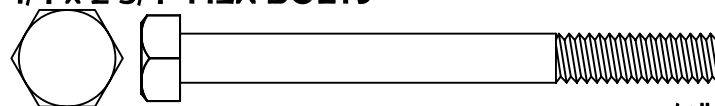

## 5/16" x 2" HEX BOLTS

2



## 1/4 x 2" HEX BOLTS

4

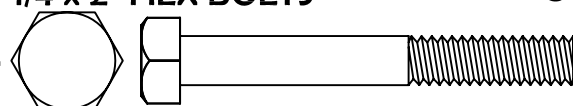

## 1/4 x 1 3/4" HEX BOLTS

9

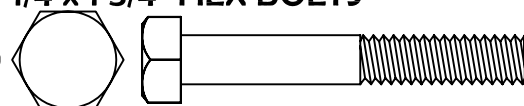

## 5/16" x 1 1/2" HEX BOLTS

4

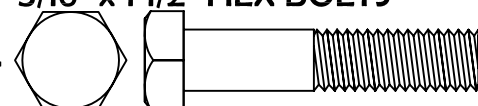

## 1/4 x 1 1/4" HEX BOLTS

3

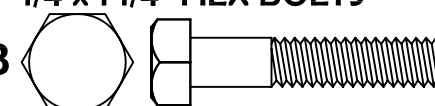

## 5/16" x 1" HEX BOLTS

10



## 5/16" T-NUTS

12

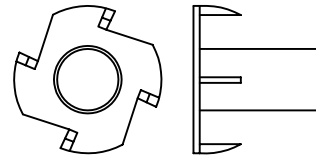

27

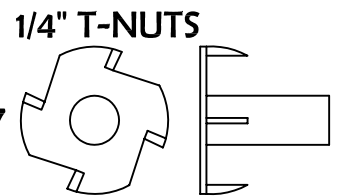

## 1/4" FINISH WASHERS

14

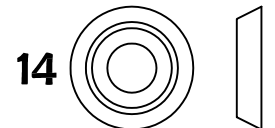

## 1/4" x 1 1/4" LAG SCREWS

4

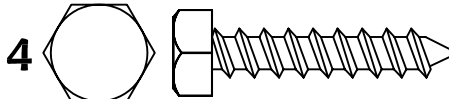

## 2 1/4" DECK SCREWS

68



## 5/16" SPLIT WASHERS

12

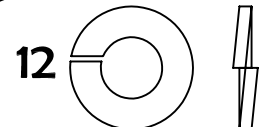

## 1" TAPPING SCREWS

14

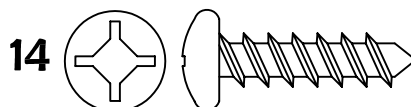

## 1 1/2" DECK SCREWS

62



## 2" TAPPING SCREWS

2



## 1/4" SPLIT WASHERS

27

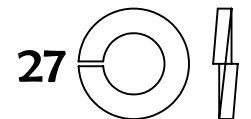

## 2 1/2" TAPPING SCREWS

4

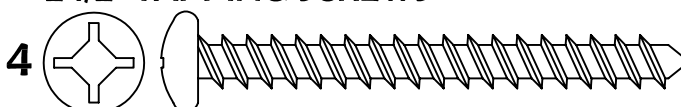

## 1/4" x 1" MACHINE TRUSS SCREW

2

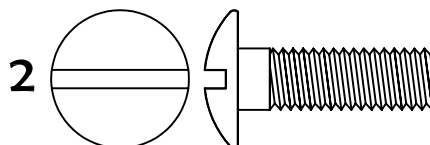

## 5/16" LOCK NUTS

2

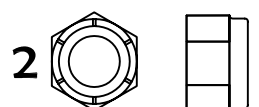

# HARDWARE IDENTIFICATION

CONT.

## GLIDER HDW BAG

5/16" x 6 1/2" HEX BOLTS

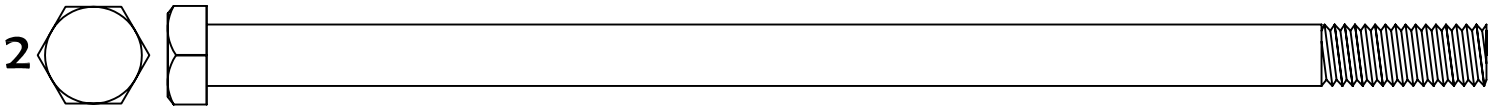

5/16" FLAT WASHERS

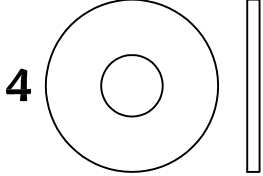

5/16" SPLIT WASHERS

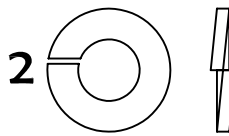

5/16" LOCK NUTS

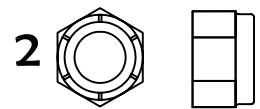

## ROCK HARDWARE BAG

3/8" FLAT HEAD BOLTS

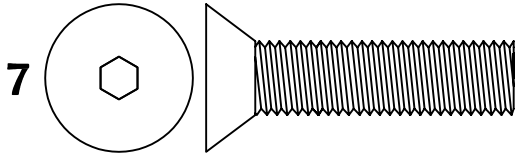

3/8" ROCK WALL T-NUTS

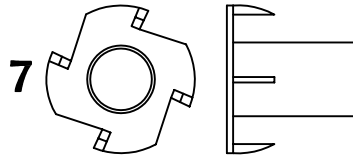

1 1/4" DECK SCREWS



1 ALLEN WRENCH

7 ROCKWALL ROCKS (NOT SHOWN)

## SWING HANGER BAG

BLACK PLASTIC SWING HANGER COVER

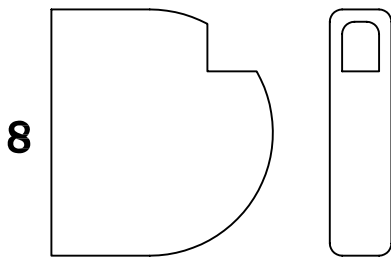

'S' HOOK

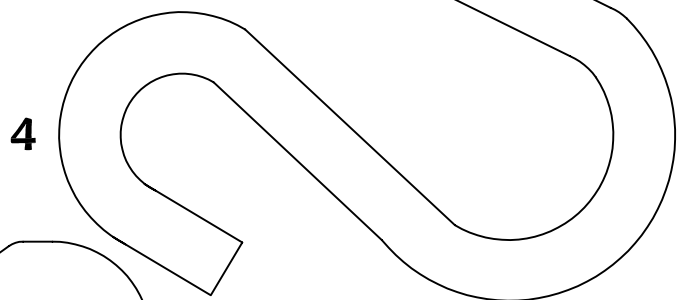

LAG SCREW SWING HANGER



## MONKEY BAR RUNG HARDWARE BAG

FENDER WASHER

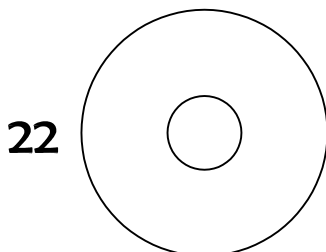

SPLIT WASHER

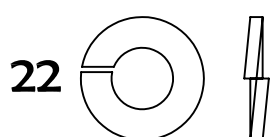

7 LONG THREADED ROD (NOT SHOWN)

4 SHORT THREADED ROD (NOT SHOWN)

BARREL BOLT

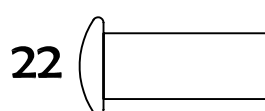

# PARTS IDENTIFICATION

ID LETTER

DESCRIPTION

QUANTITY

A --- 2x4x83 1/2" Upright (Green) --- 4



B --- 92" Rails/7 Rung Top Ladder Assembly (Green) --- 1

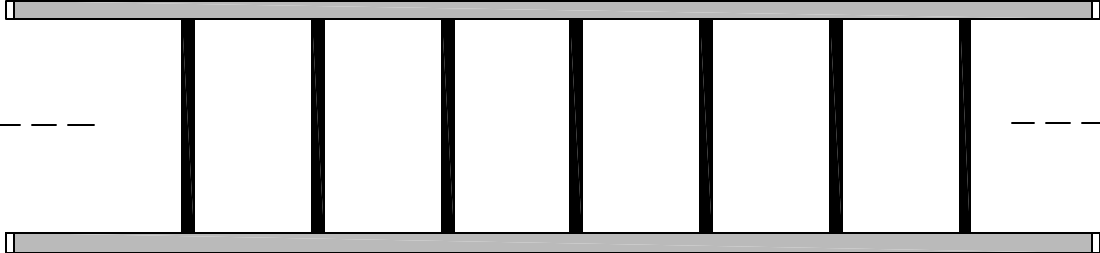

C --- 85 1/2" Rails/4 Rung End Ladder Assembly (Green) --- 1

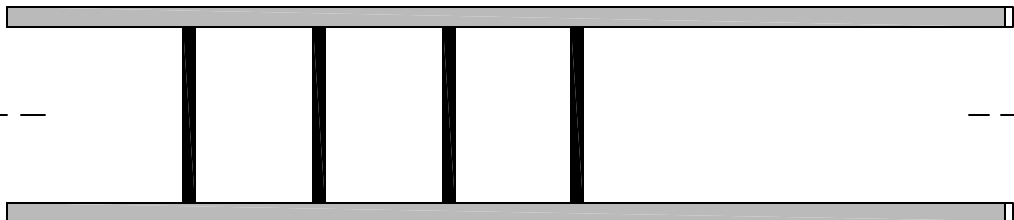

D --- 5/4x4x93" Monkey Bar Ground Beam (Green) --- 1



E --- 5/4x4x85 7/8" Fort Ground Beam (Green) --- 1



F --- 5/4x4x39 1/4" Cargo Net Ground Beam (Green) --- 2



G --- 5/4x4x26 3/8" Floor Support (Green) --- 1



H --- 5/4x4x28 3/8" Cargo Net Board (Green) --- 1

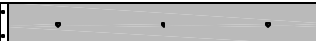

I --- 5/4x4x50 3/8" Tarp Cross Brace 4L1210 --- 1



J --- 5/4x4x34" Wall Slat 4L1211 --- 2



K --- 5/4x4x27 7/8" End Cap 4L1212 --- 2



L --- 5/4x4x26 3/8" Tarp Support 4L1213 --- 1



M --- 5/4x4x16" Tarp Upright 4L1214 --- 2





# PHASE 1

Note: Flat and level surfaces should be used for assembly

Step 1: Open all hardware bags in a box or in a secure container. Count and sort all hardware.

Step 2: Gather (4) Uprights 'A' & (2) Floor Supports 'R'.

Note: Holes offset 3/4" from side of upright 'A' should be towards inside of fort. This hole will be used later in assembly.

Step 3: Hammer t-nut into outer side of upright, and attach Floor Supports 'R' to Uprights 'A' with 2" Hex bolt, Split washers, flat washers, and T-nut through pre-drilled holes. (46 3/8" from bottom of upright).

(Do not fully tighten these bolts until after Phase 13. This will aid in the assembly process.)

Note: Use outside holes on floor supports 'R'.

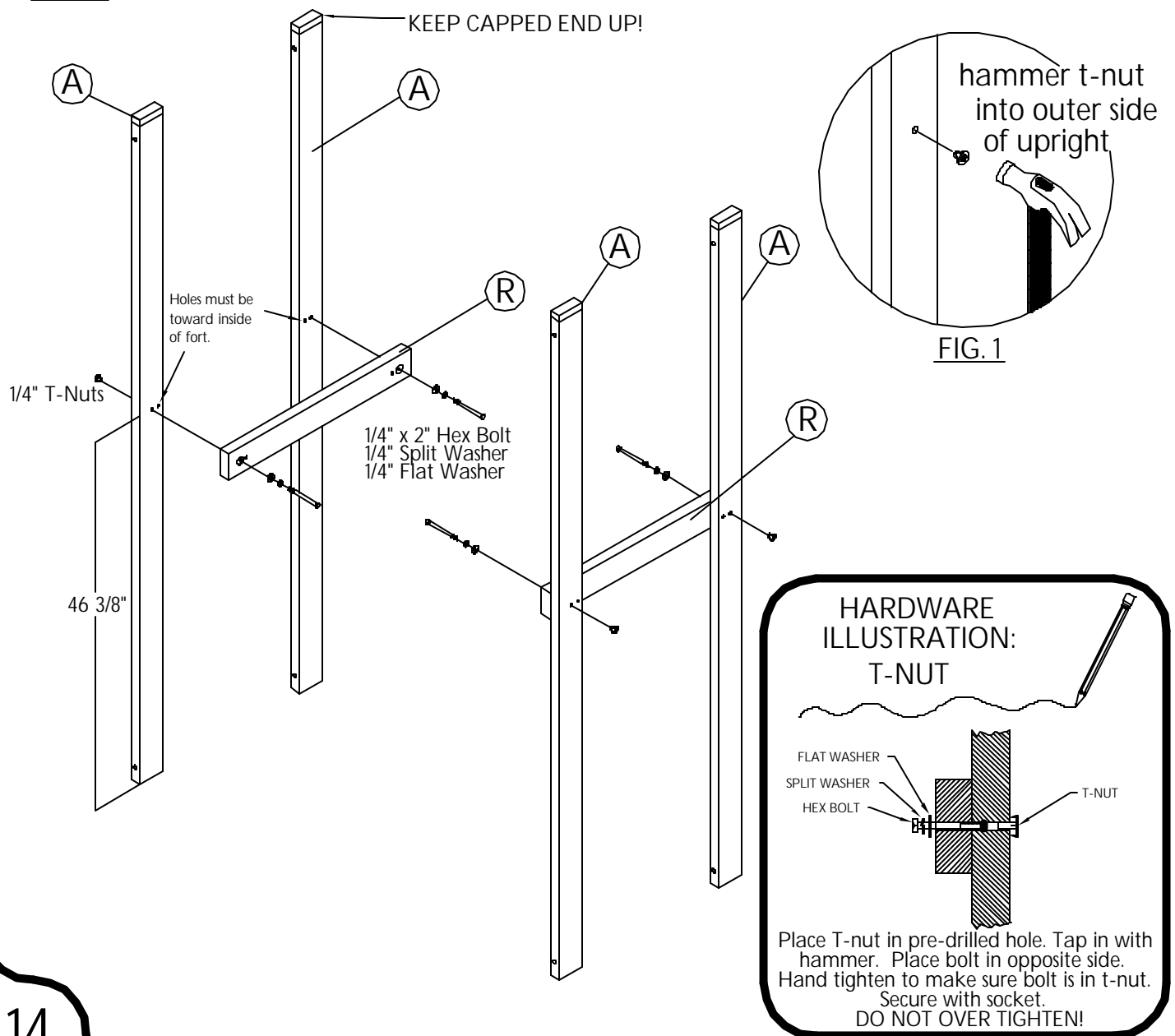



# PHASE 2

Step 1: Gather (1) Fort Ground Beam 'E', (1) Cargo Net Floor Support 'Q', (1) Floor Support 'V', & (1) Floor Support 'G'.

Step 2: Attach Fort Ground Beam 'E' & Floor Support 'G' to uprights 'A' with 1/4"x4 1/4" hex bolts, split washer, flat washer & T-nut as shown.

Note: Make sure Uprights & Floor Supports are square and level!!!!

Step 3: Attach Floor Support 'V' to uprights (bottom level with bottom of floor supports 'R') with 2 1/4" Deck Screws.

Step 4: Insert (3) 1/4" T-nuts into holes on inside of board 'Q' this must be done before board is attached. (see Fig. 2)

Step 5: Attach Cargo Net Floor Support 'Q' to uprights (level with floor supports 'R') with 2 1/2" Tapping Screws and 1/4" Flat Washers. Board position is critical. Attach where shown.

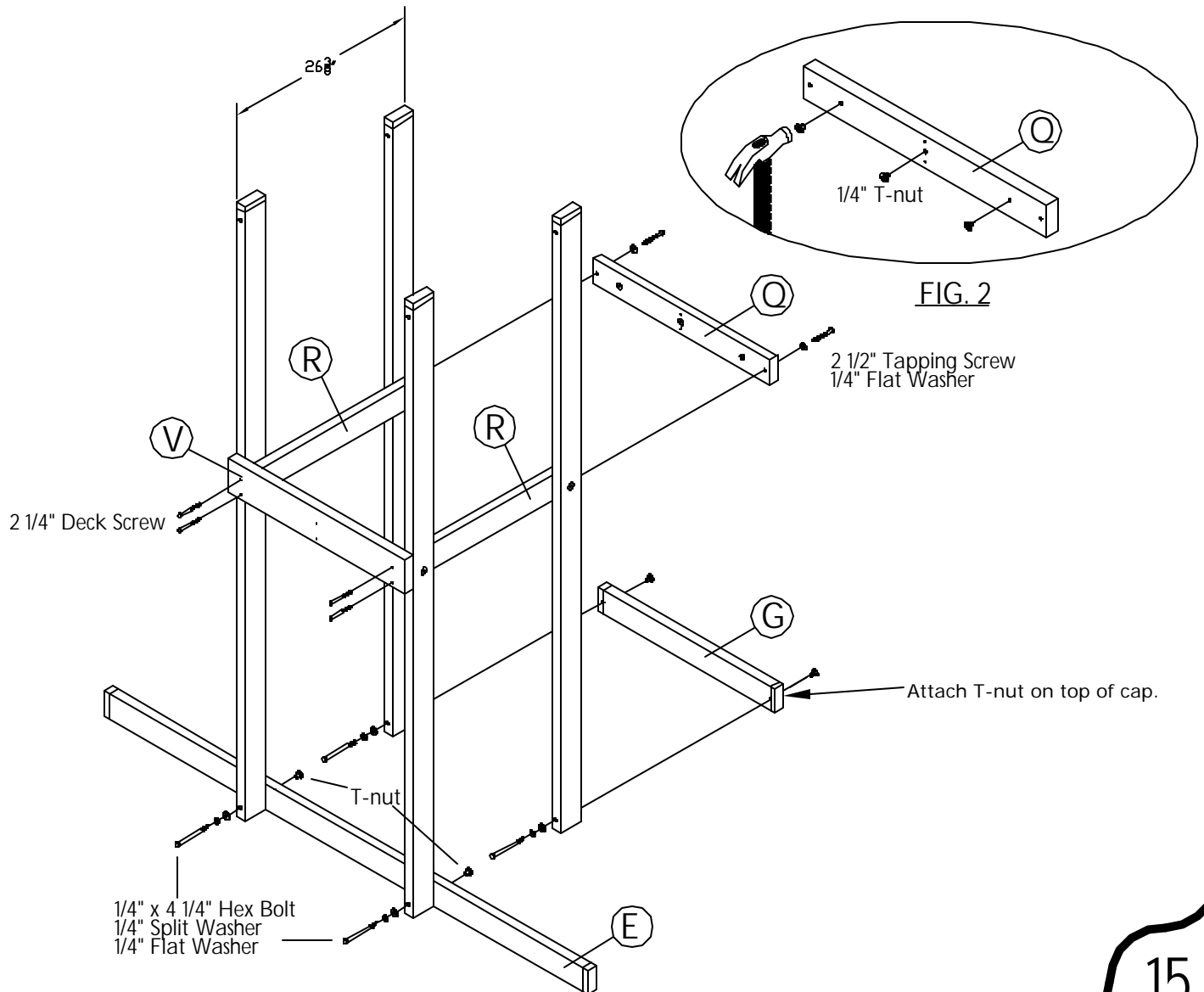

# PHASE 3

- Step 1: Gather (2) Cargo Net Ground Beams 'F' & (1) No Hole Floor Support 'S'.
- Step 2: Secure Cargo Net Ground Beams 'F' to Fort Ground Beam 'E' with 2 1/4" Deck Screws and Finished washer as shown. (see fig. 3)
- Step 3: Attach Cargo Net Ground Beams 'F' to uprights through offset pre-drilled hole with 2" Tapping Screws as shown with offset hole toward the ground. (make sure the uprights are 26 3/8" apart (outside to outside) before attaching screw)
- Step 4: Center No Hole Floor Support 'S' between pre-drilled holes on previously attached Floor Supports & attach with 2 1/4" Deck Screws. Floor Support 'S' will cover pre-installed t-nut.

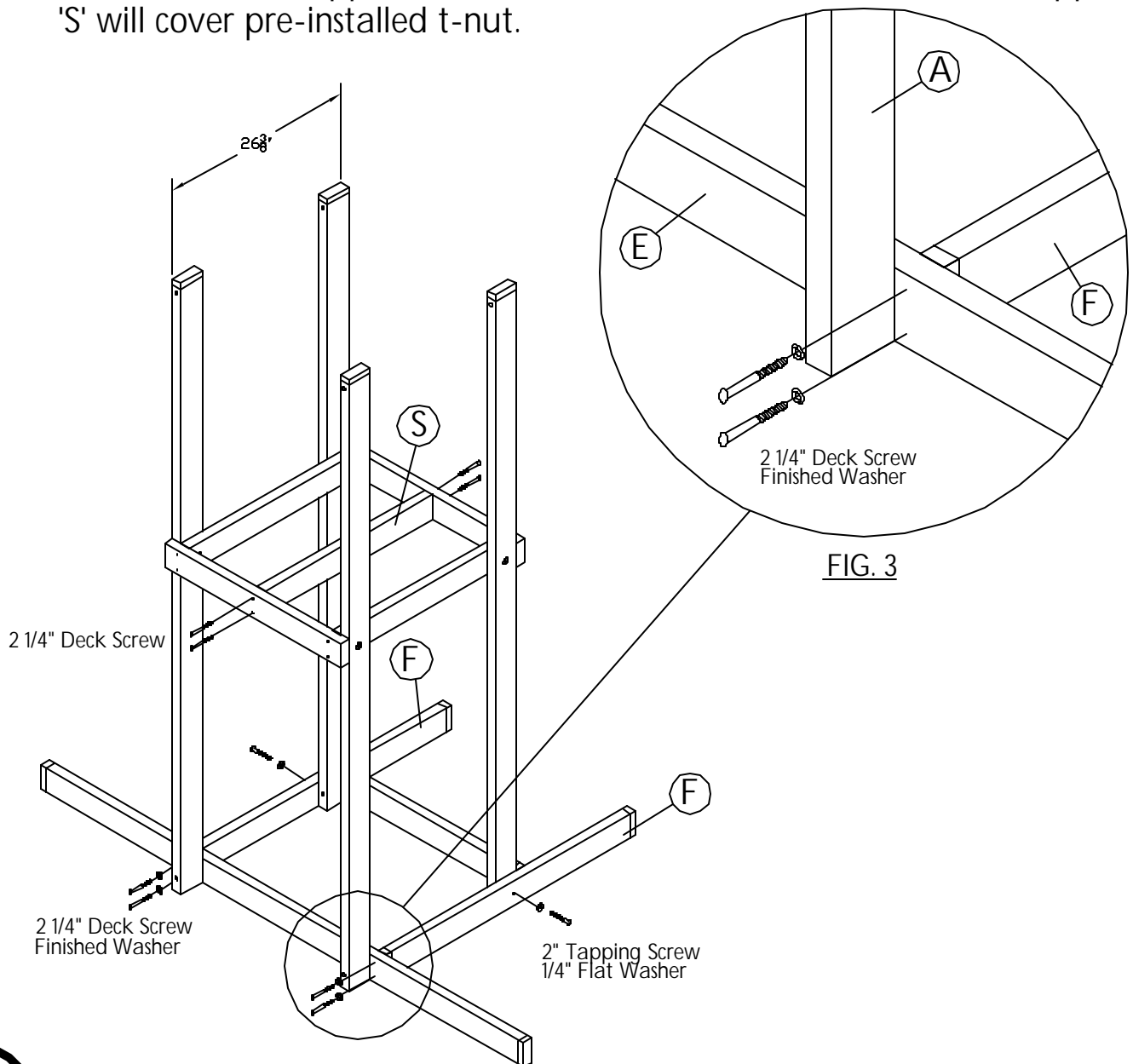

# PHASE 4

Step 1: Gather Floor Boards 'W', 'X', 'Z', 'AA' & Cargo Net Board 'H'.

Step 2: Place Floor Boards on Floor Supports as shown. Space boards approximately 1/8" apart.

Step 3: Secure boards with 1 1/2" deck screws through the pre-drilled holes.

Step 4: Attach Cargo Net Board 'H' to Ground Beams 'F' with 2 1/4" Deck Screws and Finish Washers where shown.

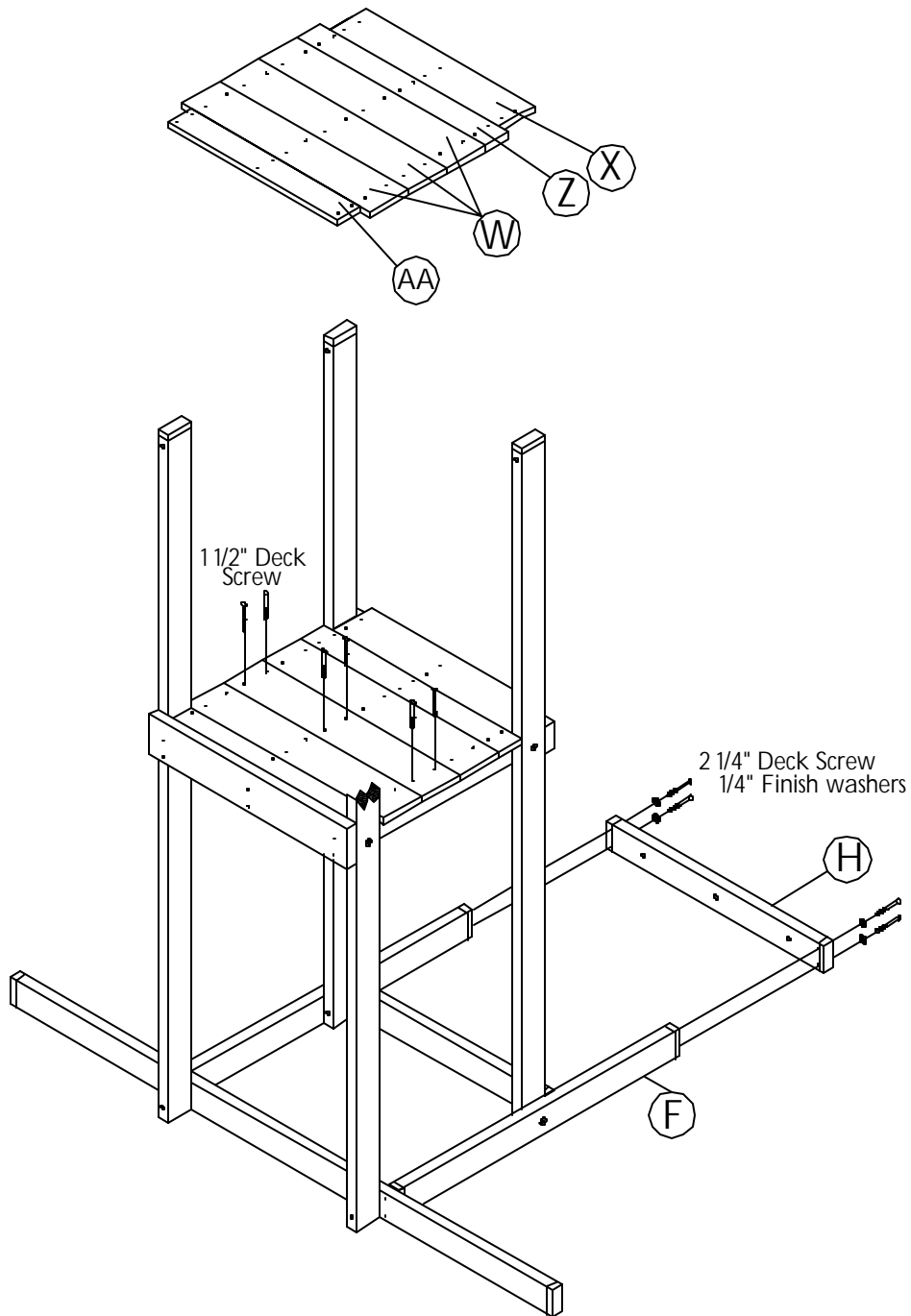

# PHASE 5

Step 1: Gather (2) Gusset Support 'T' & (4) Floor Gussets 'U'.

Note: KEEP ALL UPRIGHTS STRAIGHT AND LEVEL!!!!

Step 2: Attach Gusset Support 'T' to Uprights 'A' & Cargo Net Ground Beam 'F' with Deck Screws. (See fig. 4)

Step 3: Attach Floor Gussets 'U' to Uprights 'A' & Floor Supports 'R' with Deck Screws. (See fig. 5)

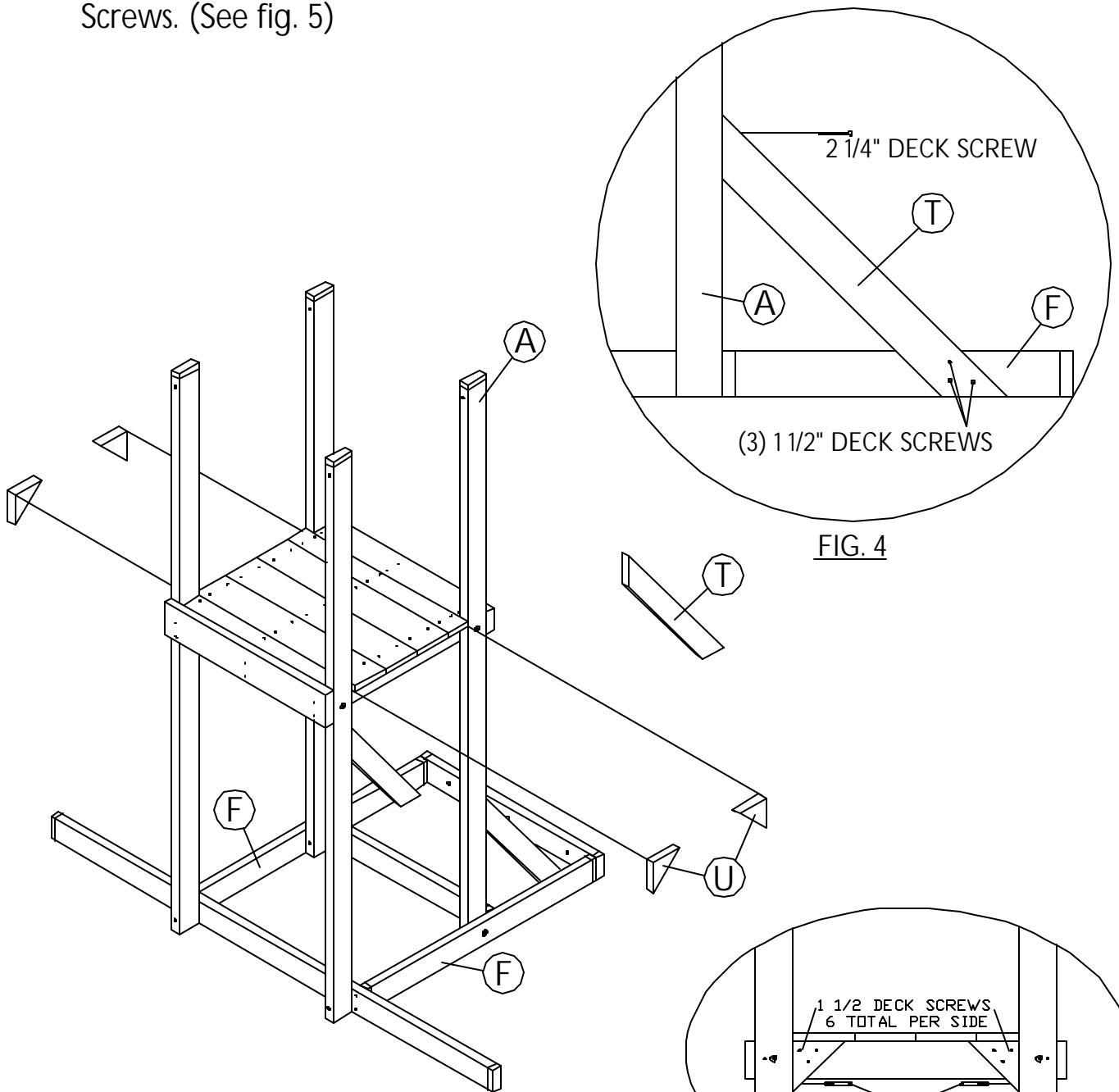

FIG. 4

FIG. 5

# PHASE 6

Step 1: Gather (2) Tarp Uprights 'M', Monkey Bar Cross Brace 'P', Tarp Cross Brace 'I', (2) End Caps 'K' & Tarp Support 'L'.

Step 2: Attach Tarp Upright 'M' to Cross Brace 'I' & 'P' with 1 3/4" Hex Bolts as shown.

Step 3: Attach End Caps 'K' to Cross Brace 'I' & 'P' with 2 1/4" Deck Screws as shown.

Step 4: Attach Tarp Support 'L' to Tarp Uprights 'M' with 2 1/4" Deck Screws.

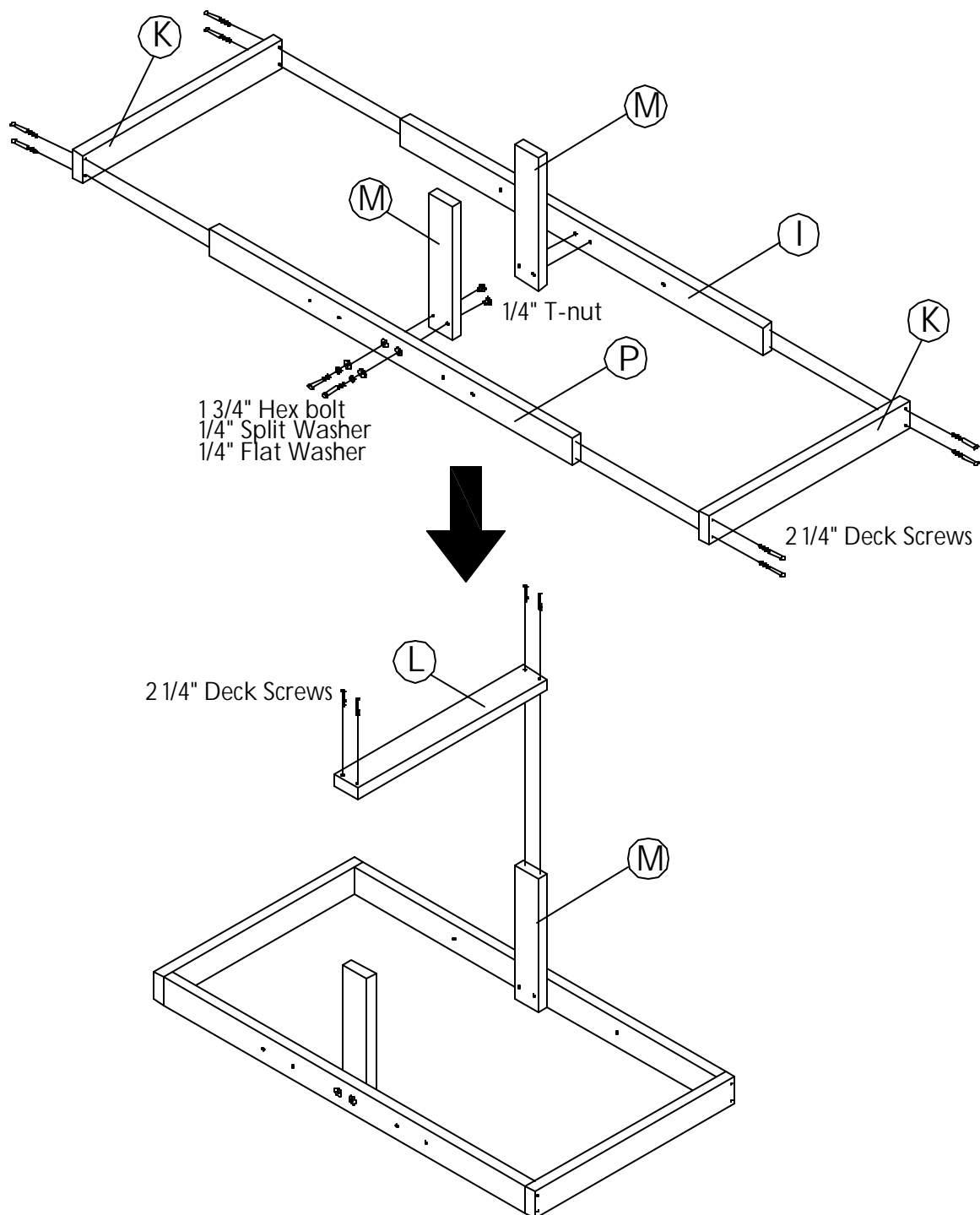

# PHASE 7

Step 1: Gather (2) Fort/Rockwall Supports 'O' and (2) L-Brackets.

Step 2: Hammer T-nut into upper end of each upright through pre-drilled hole on inside of fort where shown.

Step 3: Attach Tarp Assembly to Uprights with 4 1/4" Hex Bolts through pre-drilled holes into previously inserted T-nuts. L-Brackets attach to Monkey Bar cross brace 'P' as shown. The cross brace 'P' will attach to the same uprights as ground beam 'E'.

Step 4: Hammer T-nut to inside of floor support 'R' under floor and attach Fort/Rockwall supports (O) to Upright 'A' through offset pre-drilled hole with 4" Hex Bolts. (see Fig.6)

Step 5: Attach Fort/Rockwall Supports 'O' to Ground Beam 'E' through pre-drilled hole with 1 3/4" Hex Bolts.

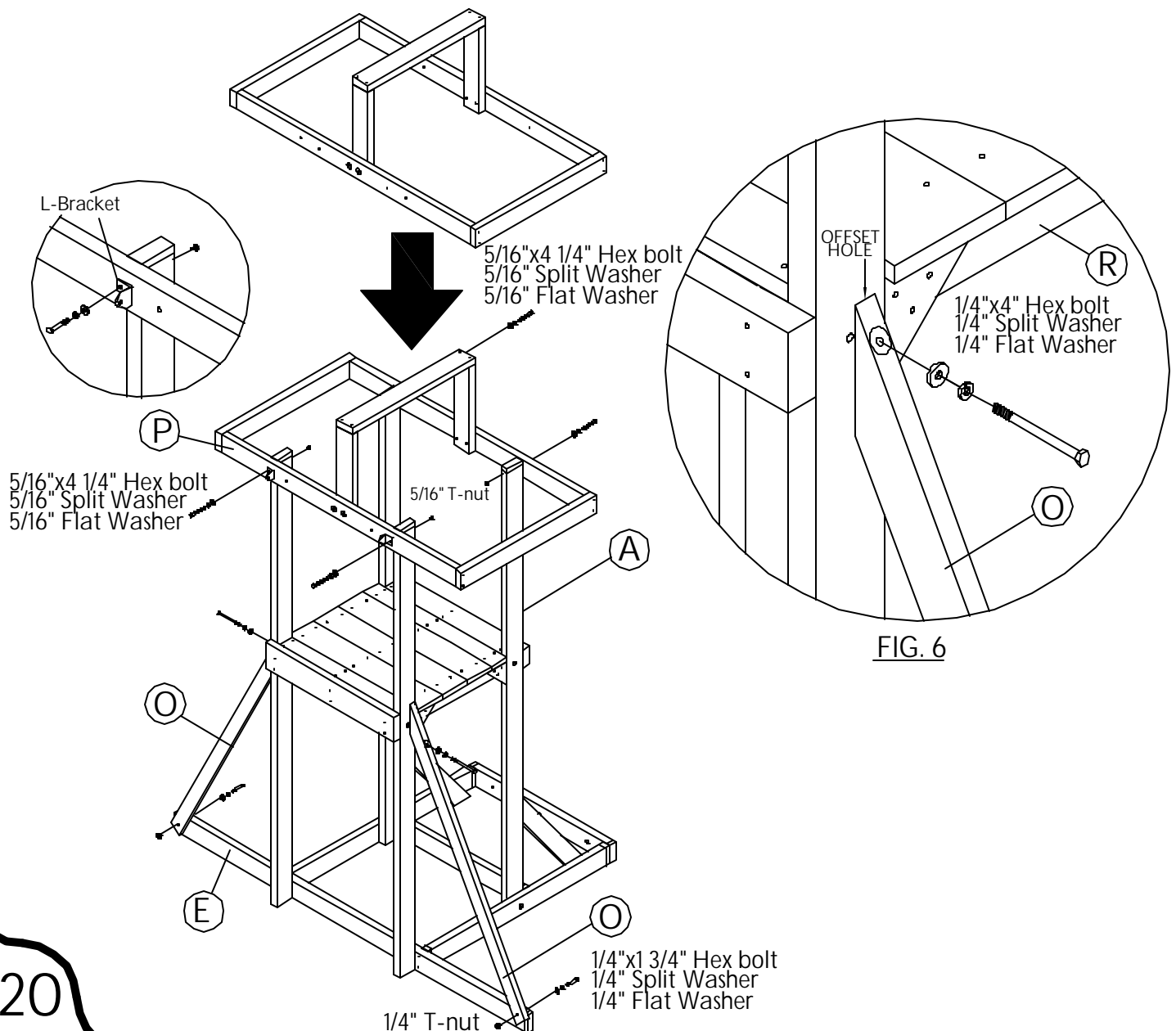

# PHASE 8

Step 1: Gather Top Ladder 'B', End Ladder 'C', (2) Triangle Braces & (1) Bottle of Superlock Nutlock

Step 2: Secure Top Ladder Rails & End Ladder Rails with Barrel Bolt & Threaded Rod. (See fig. 7 & fig. 8)

Note: Insert one end of Threaded Rod into Barrel Bolt. Place 2 drops of Superlock Nutlock on end of Threaded rod. Place Fender Washer and Split Washer on bolt, then insert through rung and secure with Superlock nutlock and second Barrel Bolt. Tighten both ends but do not overtighten. (do this for each rung) \*see installation tip below\*

Note: Top Ladder Threaded Rod: Long Rod  
End Ladder Threaded Rod: Short Rod

Step 3: Attach Triangle Braces to Top Ladder with hardware specified in fig. 9.

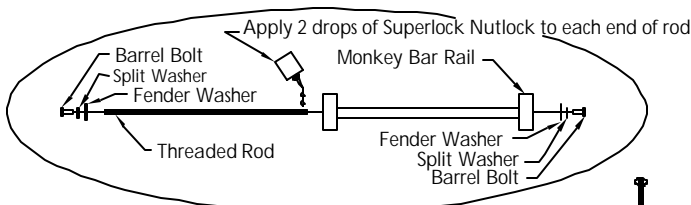

FIG. 7

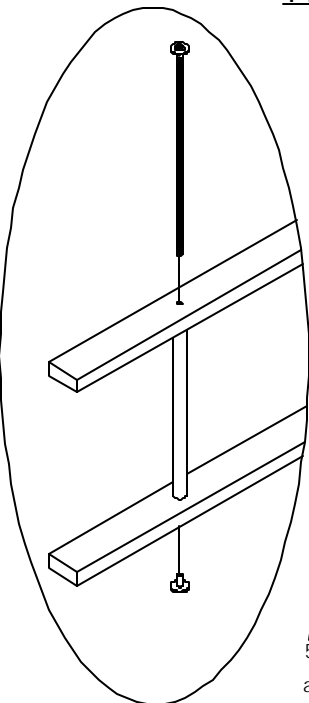

FIG. 8

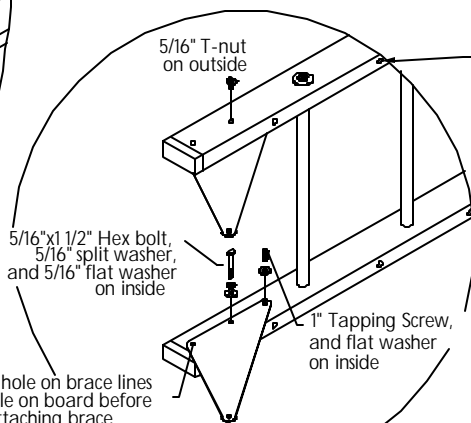
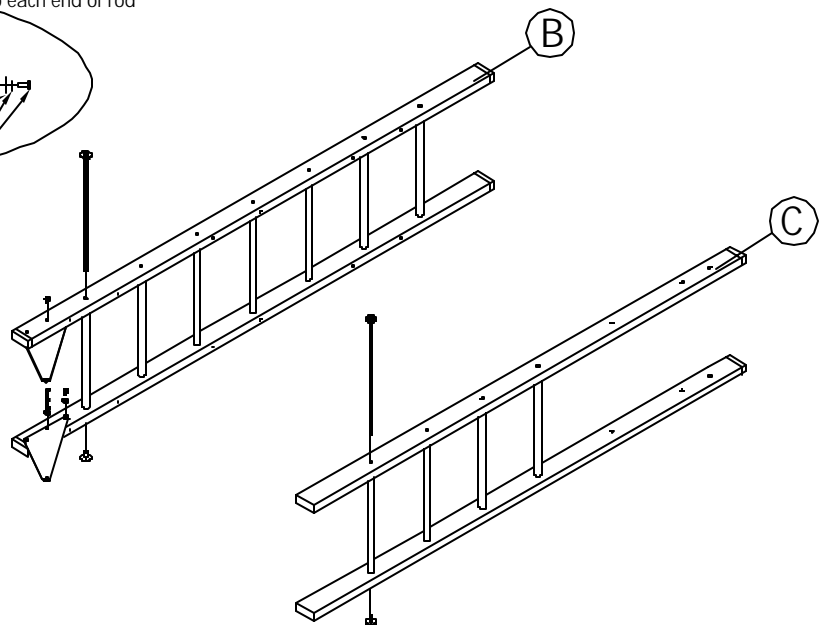

FIG. 9

Note: Pilot holes for swing hanger should be on this side.

### \*INSTALLATION TIP\*

Threaded Rod insertion is made easier when barrel bolt is only placed on rod approximately 2 threads and monkey bar is placed on its side as shown. Rod should drop into hole on other side with just a few tries, then start other barrel bolt and tighten both ends.

# PHASE 9

Step 1: Screw Lag Screw Swing Hangers into pilot holes on top ladder in pattern as shown below.

Put Swing Hangers in circled holes!

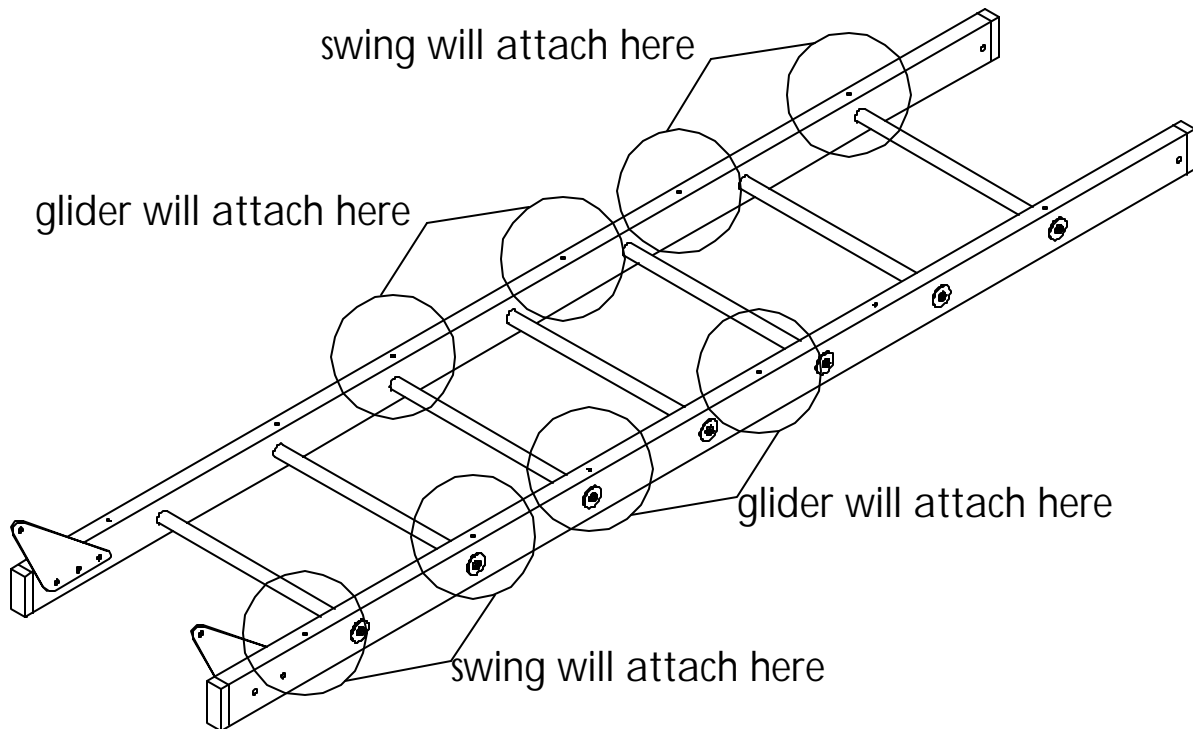

## HARDWARE ILLUSTRATION: SWING HANGER

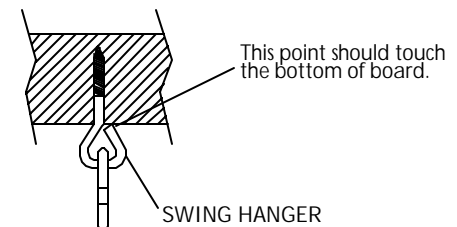

The Lag Screw Swing Hanger must be screwed in so that the tip of the swing hanger is touching the receiving board.  
NOTE: Triangular bend on swing hanger must run parallel with board



# PHASE 10

Step 1: Gather Ladder assemblies, (2) Angle Braces 'N' and Ground Beam 'D'.

Step 2: Attach End Ladder to Top Ladder with Triangle Braces through pre-drilled holes. See fig. 10 for hardware.

Step 3: Attach Angle Braces 'N' to Ground Beam 'D' as shown.

Step 4: Attach Angle Braces 'N' to end ladder as shown.

Step 5: Attach Ground Beam 'D' to End Ladder with 2 1/2" Tapping Screws.

Note: Do not overtighten bolt so that end protrudes through t-nut. End must be flush with t-nut (See Below)

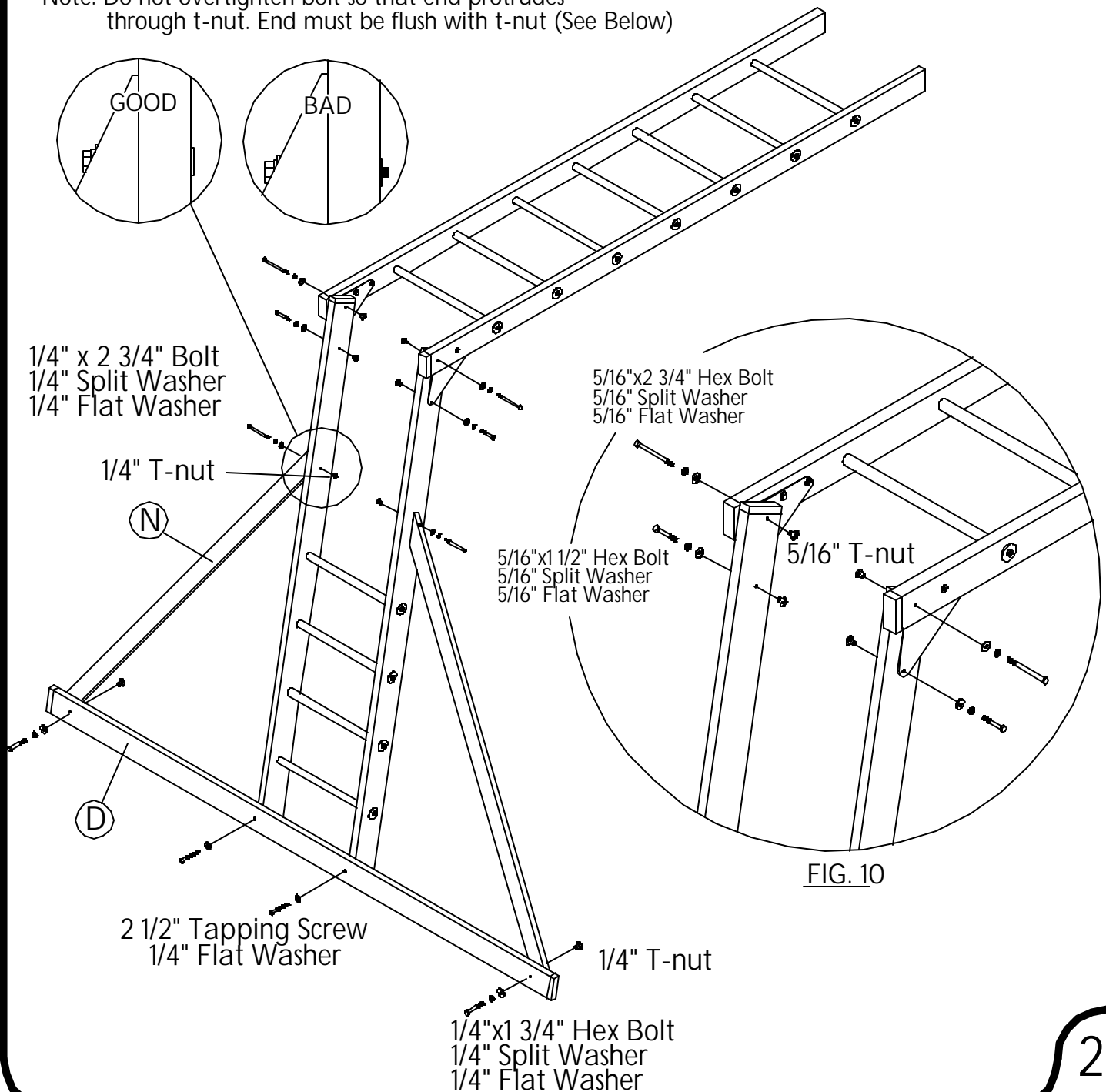

# PHASE 11

Step 1: Attach (2) L-Brackets to Monkey bar cross brace 'P' with 5/16" x 1" hex bolts.

See Fig. 11.

Step 2: Attach Monkey Bar to unit through L-Brackets with 5/16" x 2" Hex Bolts

See Fig. 12.

Step 3: Attach Adventure Playsets ID Sticker to outside of monkey bar as shown.

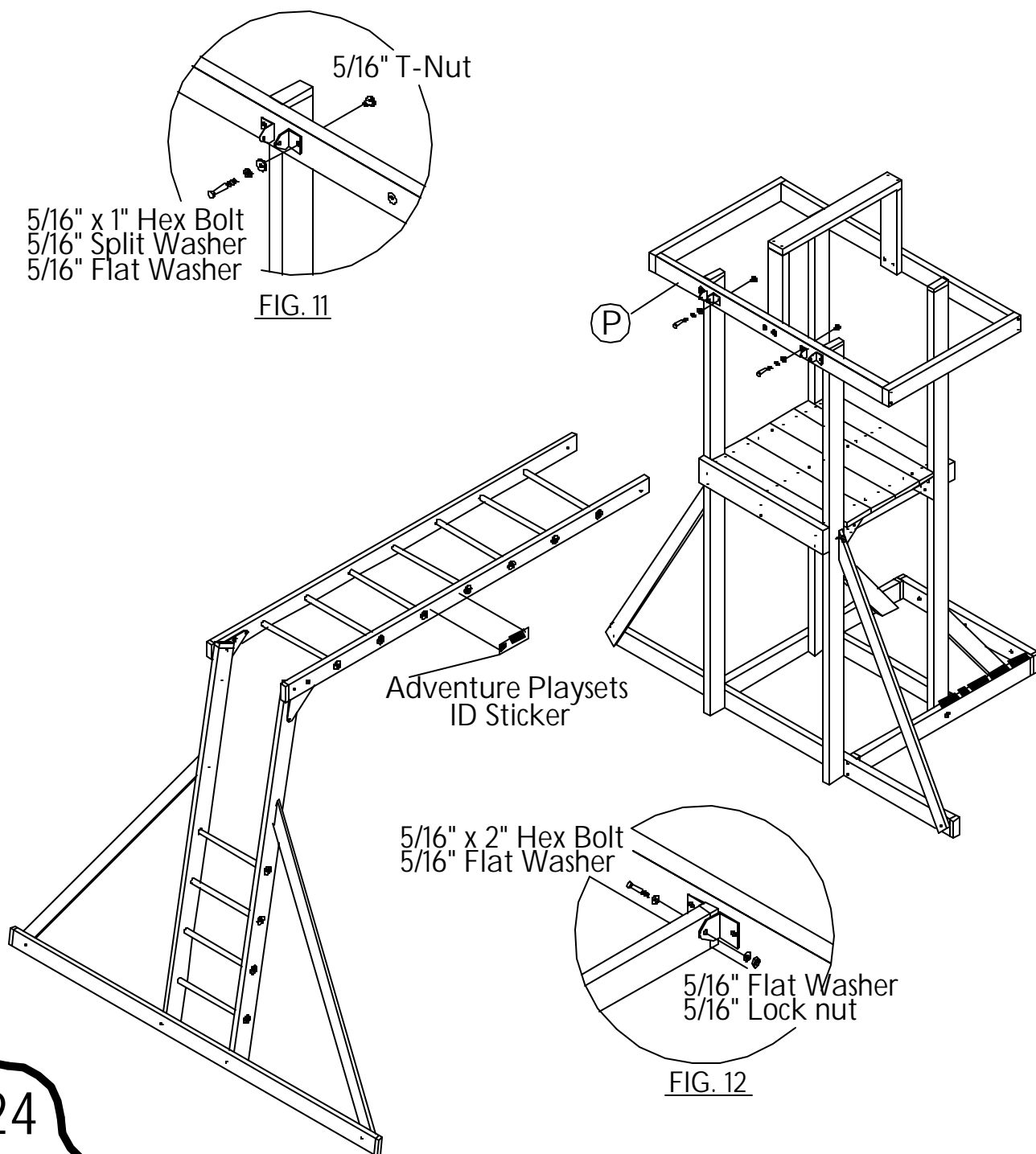

# PHASE 12

Step 1: Attach (2) wall slats 'J' to uprights 'A' with (2) 2 1/4" deck screws and finish washers as shown.

Step 2: Attach wall slats to cross brace 'P' and floor support 'V' with 1 1/2" deck screws as shown.

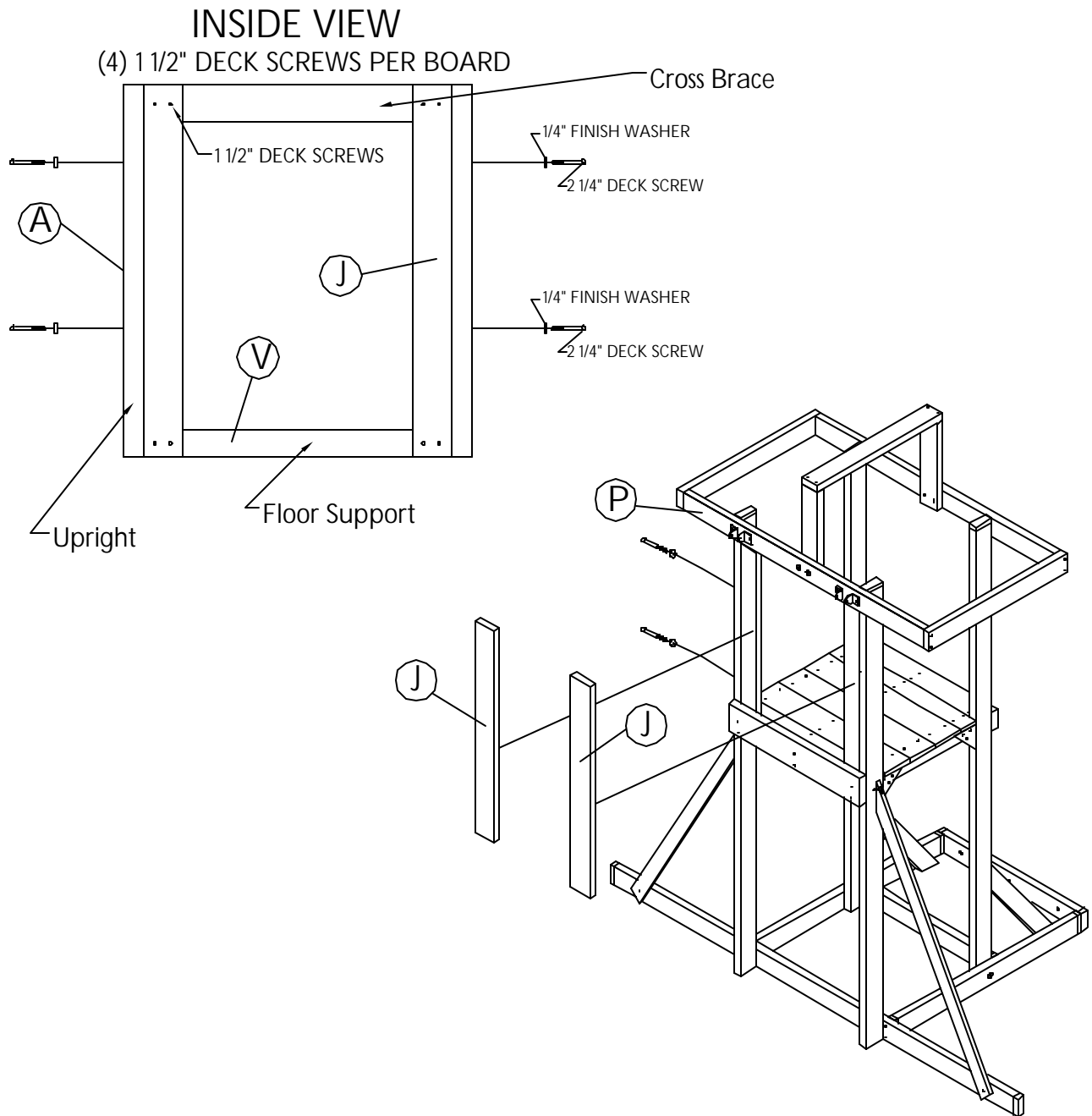

# PHASE 13

Step 1: Gather (1) Rockwall Angled Support 'O', Cargo Net, & Tarp.

Step 2: Attach 1/4" T-nut to inside of Floor Support 'R'.

Step 3: Attach Support 'O' to upright with 4" Hex bolt as shown.

Step 4: Attach ground beam 'AB' to brace 'O' with 1 3/4" hex bolt, washers, and t-nut as shown.

Step 5: Attach Ground Beam 'AB' by running (2) 2 1/4" deck screws through (2) finish washers and ground beam 'F' and into end of 'AB' as shown below.

Step 6: Attach Cargo net to floor support 'Q' with 1 1/4" Hex Bolts.

Note: T-nuts were attached to inside of board in Phase 2.

Step 7: Pull cargo net tight, thread through pre-drilled holes, and tie a secure knot at bottom.

Step 8: Drape tarp over tarp support 'L' and end caps 'K'. Attach to inside of end caps 'K' with (3) 1" tapping screws per side. See Fig. 13 & 14.

Step 9: Make sure all bolts are tight and tighten bolts on Floor Supports from Phase 1.

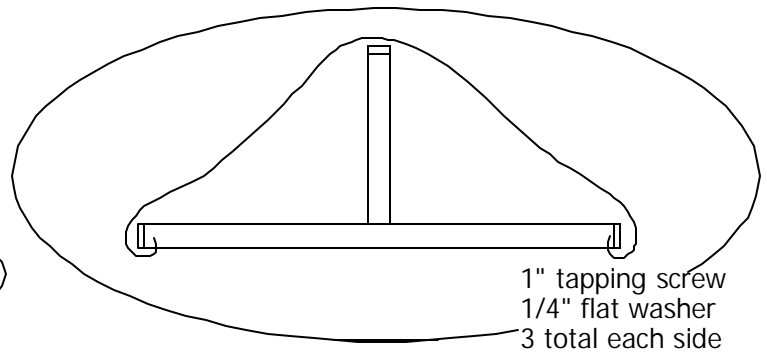
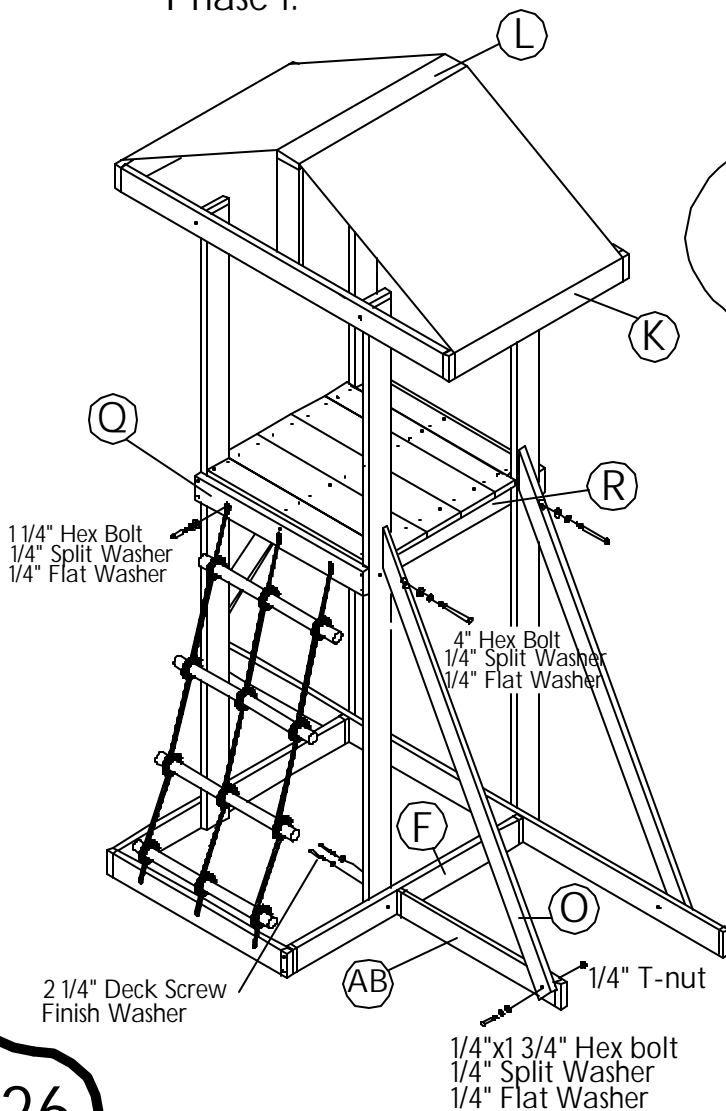

FIG. 13

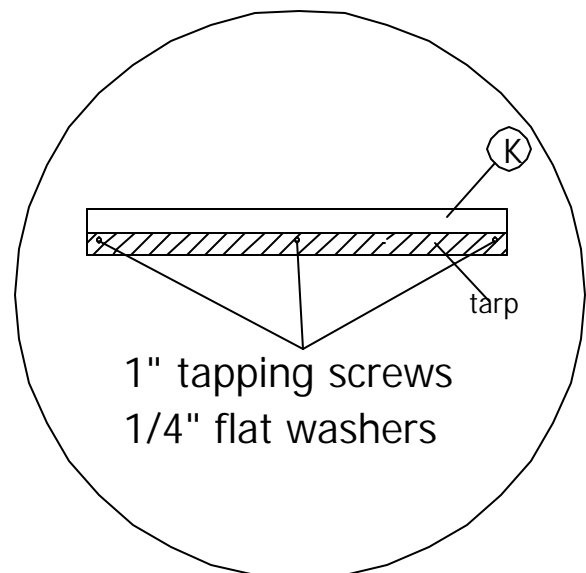

FIG. 14

# PHASE 14

Step 1: Gather (7) Rockwall Boards 'Y' and (2) Yellow grab handles.

Step 2: Apply (2) drops of Superlock Nutlock to ends of Rock bolts and attach rocks with 3/8" rock hardware by using provided Allen wrench. (See Fig. 15)

Step 3: With a hand screwdriver, secure Rock to Rockwall board by using a 1 1/4" Deck Screw through pre-drilled hole in rock. DO NOT OVERTIGHTEN

Step 4: Attach Rockwall Boards to Rockwall Braces with 2 1/4" deck screws.

Start by placing (1) rockwall board on top of ground beams 'E' and 'AB' and work up to attaching top rockwall board. Space each board 2" apart and alternate position of rock from left side to right side as shown.

Step 5: Attach the (2) yellow grab handles to the uprights 15" down from top of upright to top of handle as shown. (see Fig. 16)

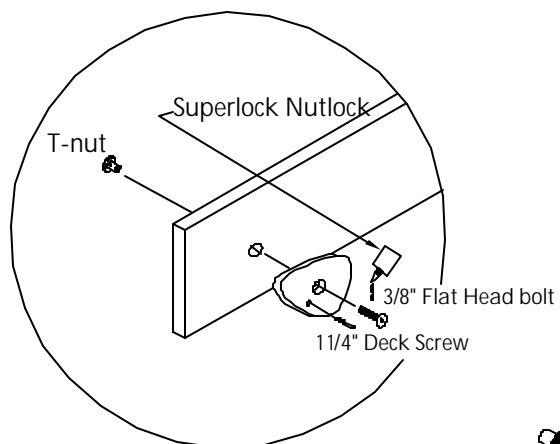

FIG. 15

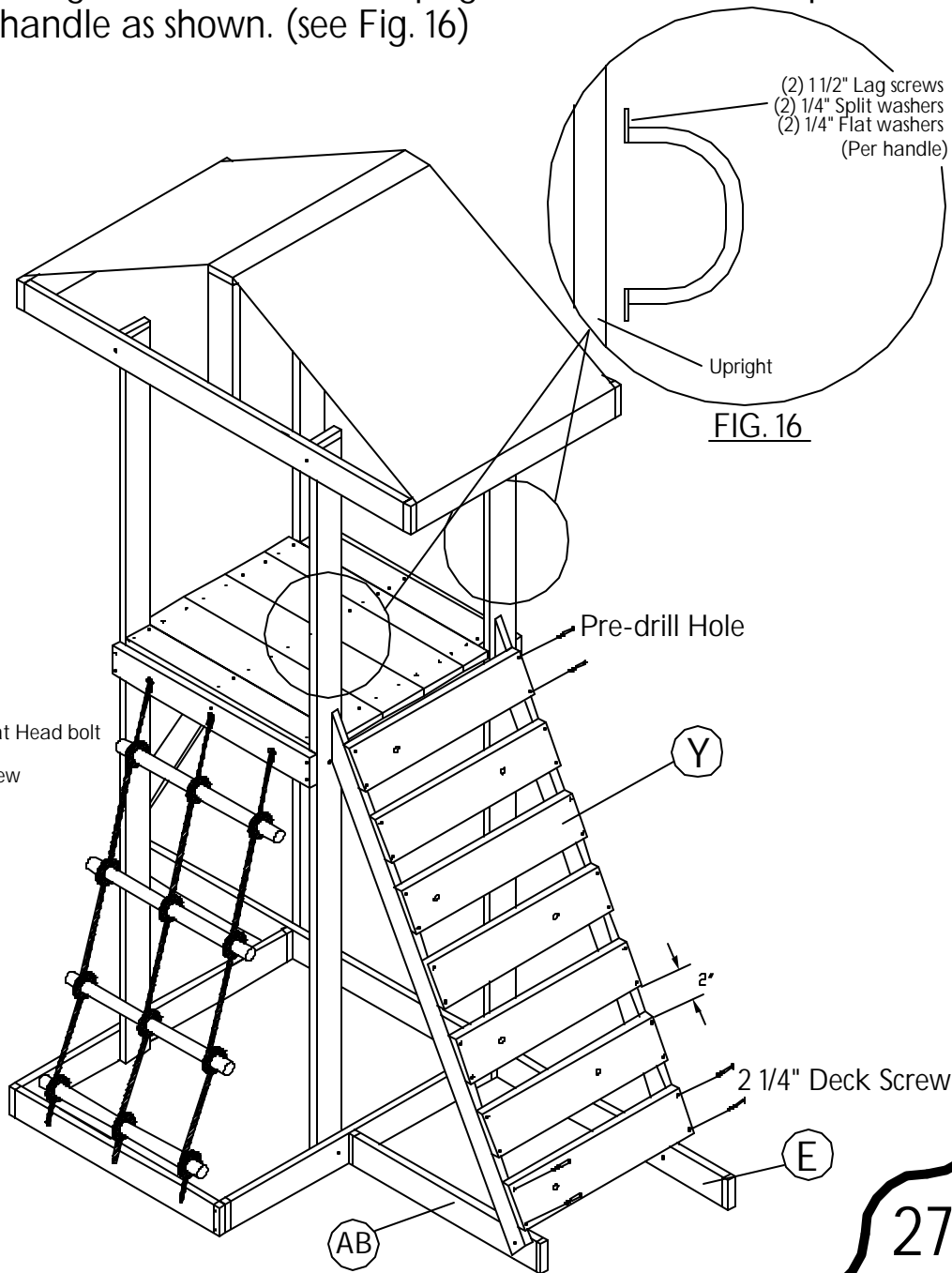

FIG. 16

# PHASE 15

Step 1: Attach the S-hooks to the swing seats. Slide the bigger end of the S-hook into the hole located on swing seat. Close S-hook with hammer as shown in Fig. 17.

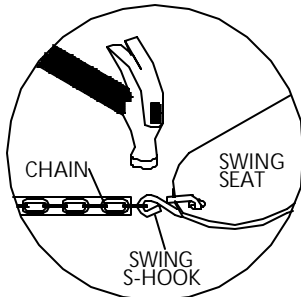
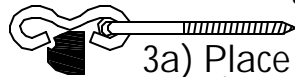

FIG. 17

Note: The bigger opening on the S-hook will be the end that will attach to the swing seat.

Step 2: Attach 57" chain to smaller end of S-hook and close with hammer.

Step 3: Attach plastic swing hanger cover to swing hanger as shown below.



3a) Place swing hanger through opening of cover.

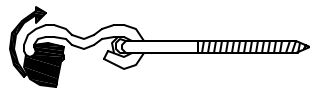

3b) Work cover around the curves of the swing hanger

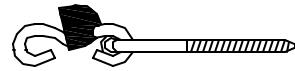

3c) Loop chain over swing hanger, flip cover over and place over opening.

HARDWARE ILLUSTRATION:  
'S'-HOOK

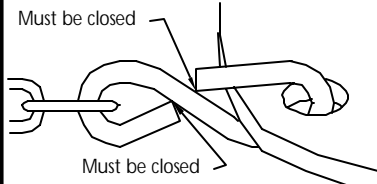

NOTE: FOR YOUR CHILD'S SAFETY, MAKE SURE THAT THE HOOKS ARE COMPLETELY CLOSED AND THE CHAINS DO NOT PULL OFF THE HOOKS.

Step 4: Attach opposite end of chain to swing hangers.

\*INSTALLATION TIP\*

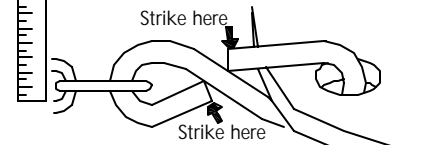

When closing S-Hook, strike hook on outermost edge. Its not how hard you strike the hook, but consistent hammering heats the metal and closes the hook.

# PHASE 16

Step 1: Insert glider seat into glider arms & attach w/ (2) 6 1/2" hex bolts, (4) 5/16" flat washers & (2) 5/16" lock nuts.

Step 2: After assembly is complete, attach glider to swing hangers located on monkey bar. (see Phase 9)

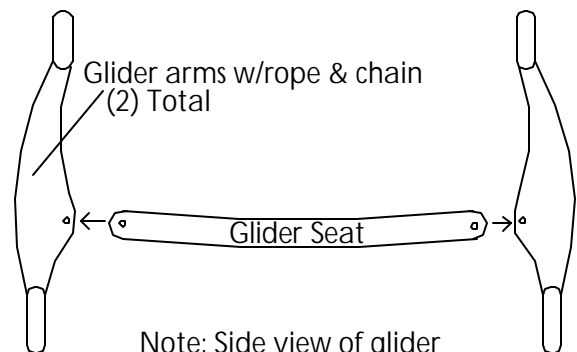

Note: You may need to adjust the height of the glider with the chain so that the glider is at least 8" off the ground.

# PHASE 17

Step 1: Center wave slide in opening opposite the rockwall.

Step 2: Drill a 5/16" hole through the holes on the slide and through the fort floor.

Step 3: Insert a 1/4" T-nut into each hole on underside of floor and insert 1/4"x1" Machine truss screws through holes and into t-nuts and tighten.

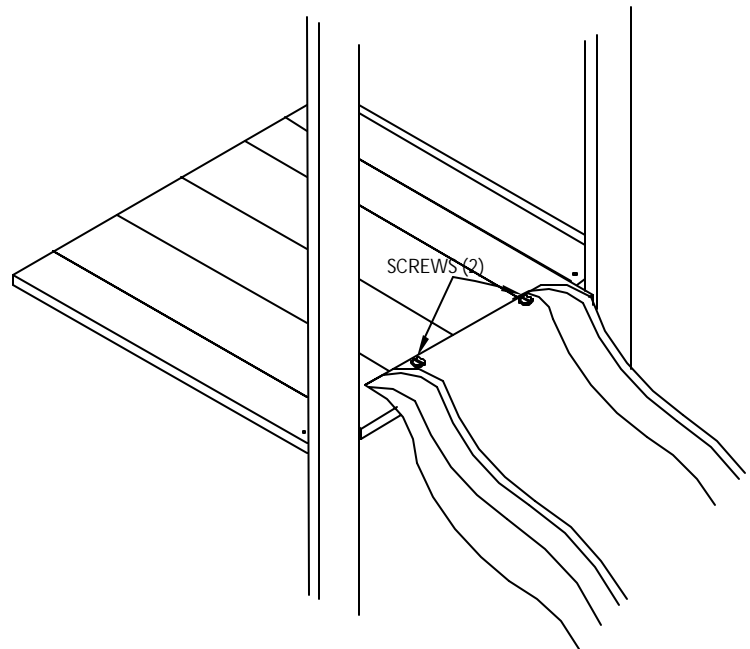
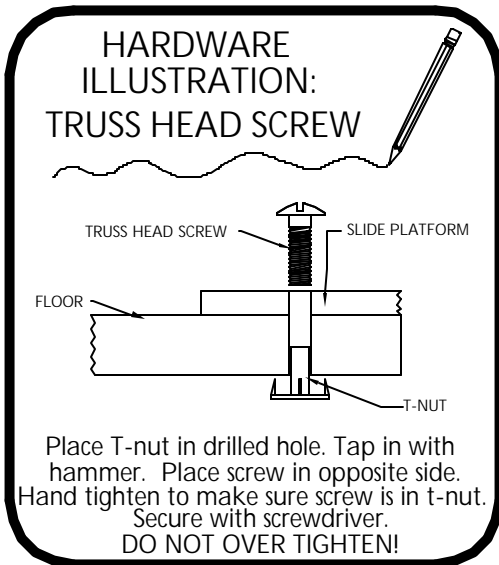

# PHASE 18

Step 1: Drive Stakes into ground where shown below and attach with 1" Tapping Screws and 1/4" Flat washers as shown in Fig.18.

Note: Failure to use stakes can void warranty & cause injury.

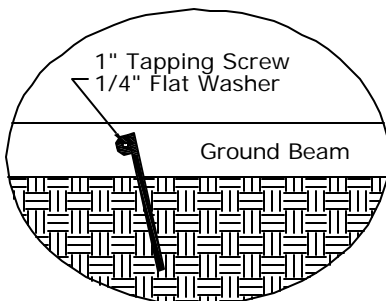
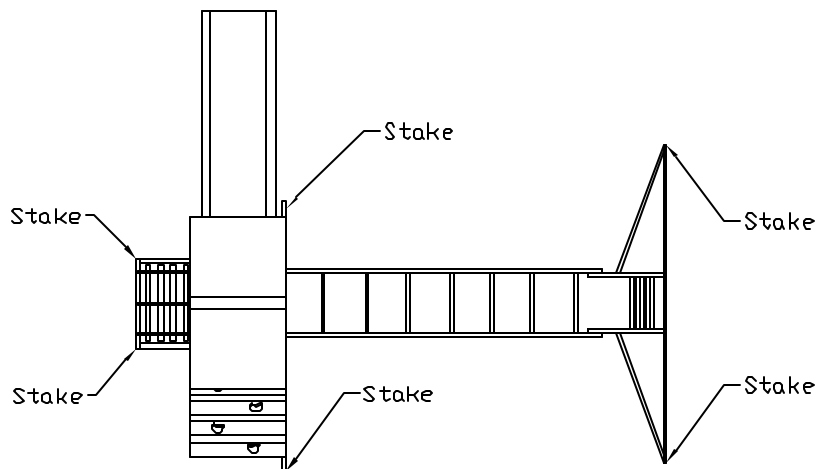

FIG. 18



Final Step: Double check and make sure every bolt, screw and nut is tight, every board is secure and enjoy.

# CUSTOMER NOTES

---

---

---

---

---

---

---

---

---

---

---

---

---

---

---

---

---

---

---

---

---

---

---



# Limited Warranty

Adventure Playsets Inc. insures to the original owner of our product, that the components of our set are free from defect in materials and will be warranted for one year from the date of purchase. In addition, all wooden components will be warranted against rot or insect damage for 12 Years to the original owner. All non-wood components will carry a one-year warranty only.

All defective parts that are discovered and reported in the first thirty days after purchase will be replaced at no charge to the registered customer. After thirty days of purchase shipping and handling charges for replacement warranty parts will be passed on to the consumer.

All returned goods will be accessed by our customer service department. We will not accept any goods without an authorization code. Our customer service department will give out all codes. Failure to supply authorization code with shipment will void all said warranty. Our customer service department can be reached at 1-800-856-4445.

## **This Limited Warranty does not cover the following:**

- ❑ The cost of labor required to re-install or disassemble the defective component.
- ❑ The cost of air freight
- ❑ The cost of freight after the initial 30 days from purchase.
- ❑ Cosmetic defects that do not affect the structural integrity of the play center.
- ❑ Any abnormal conditions such as vandalism, improper installation, misuse or abuse, or improper maintenance.
- ❑ Damage done by nature such as wind, lightning, severe weather, etc...
- ❑ Natural defects of wood such as warping checking or any other physical properties of wood that do not present a hazard.

Adventure Playsets products have been carefully designed to insure your child's safety. Any modifications to your playsystem could result in serious injury as well as void all warranties.

**Our playsets are designed for Residential use only, for children between the ages of 3 and 10, for a single-family dwelling.**

**Commercial use such as nurseries, parks or schools, voids all warranties.**

# Warranty claim procedure

If you are confident that your playsystem has been installed and maintained properly, and you have a warranty claim, proceed with the following steps:

1. We will need copy of your proof of purchase (Dealer sales receipt only.)
2. We require a brief written description of the warranty issue.
3. Photos of warranted parts and of the entire play system.

If any of the above steps are not completed, there may be delays in the completion of your claim, or possibly warranty cancellation.

Mail information to:

Adventure Playsets  
14201 I-27  
Amarillo, Texas  
79119

or email at  
[custservice@adventureplaysets.com](mailto:custservice@adventureplaysets.com)

Our customer service department will review the claim and make contact with the customer by mail or by phone. The customer will only pay for shipping and handling to and from factory if warranty is approved.

1-800-856-4445  
Service department hours Monday thru Friday 9am to 5pm  
Saturday 9am to 2pm  
Central standard time

# Customer Registration Card

Name: \_\_\_\_\_

Address: \_\_\_\_\_

City: \_\_\_\_\_ State: \_\_\_\_\_ Zip: \_\_\_\_\_

Home Phone \_\_\_\_\_

Date of Purchase \_\_\_\_\_

Vendor Name \_\_\_\_\_

City: \_\_\_\_\_ State: \_\_\_\_\_ Zip: \_\_\_\_\_

Unit Model: The Ventura 1-AP008

Please check the box below.

How old are you?

18-30       31-43       44-56       Older than 56

What is your level of income?

Less than \$10,000     \$10,001-\$25,000     \$25,001-\$50,000     \$50,001-\$75,000  
 More than \$75,000

How would you rate the quality of our product?

Above Average     Average     Fair     Poor

How would you rate the ease of assembly of our product?

Above Average     Average     Fair     Poor

How would you rate our instructions?

Above Average     Average     Fair     Poor

Would you recommend our product to friends & family?

Yes       No

How old are your children?

3-4       5-6       7-8       9-10

Where did you hear about us?

Friend       Store Display       Advertisement       Internet

Comments: \_\_\_\_\_  
\_\_\_\_\_  
\_\_\_\_\_

# Customer Registration Card

**Do not forget to send in your registration card to the factory.  
This card will validate your time of purchase for warranty items.**

Fold here

---

**Place  
stamp  
here**

**Adventure Playsets  
14201 I-27  
Amarillo Texas, 79119**